

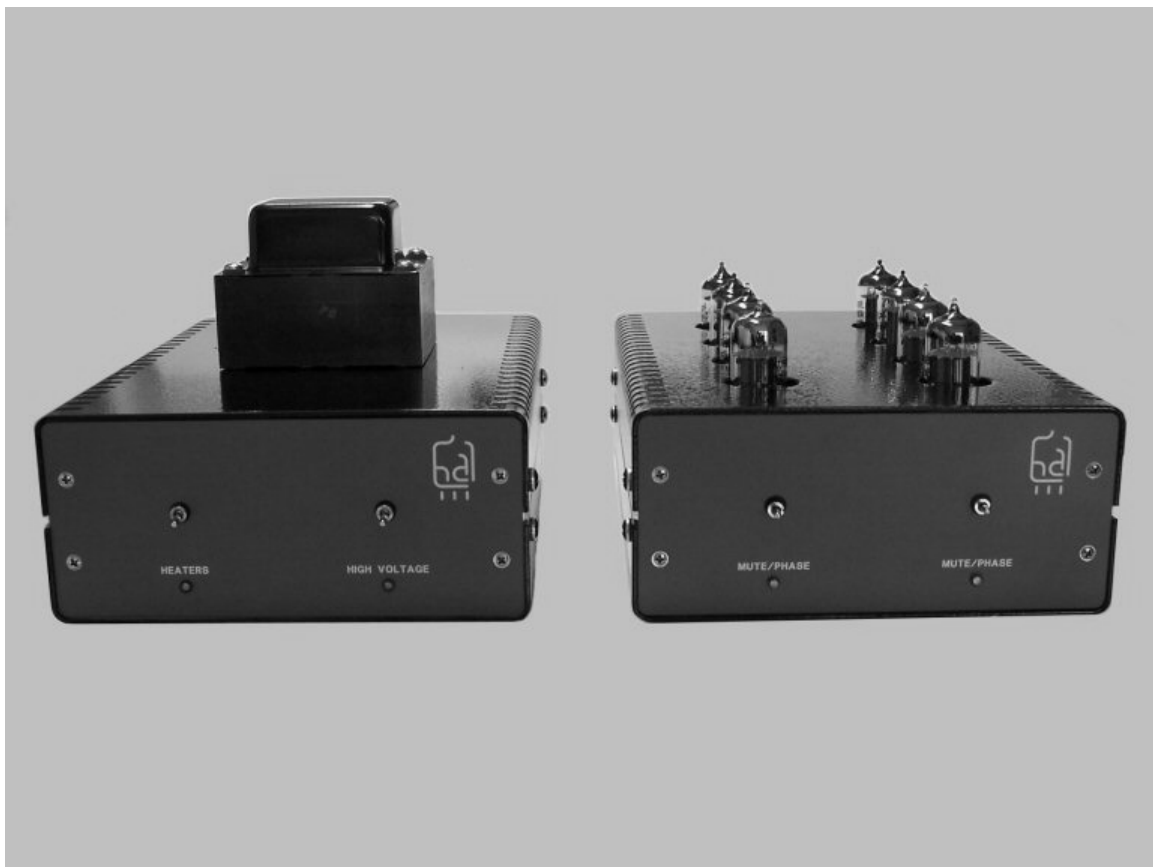

TRUMPET

Vacuum Tube MM Phonostage



Made in USA

Copyrights & Trademarks

© Copyright Hagerman Audio Labs 2008. All rights reserved. No part of this document may be photocopied, reproduced, or translated to another language without the prior written consent.

Disclaimer

The information contained in this document is subject to change without notice. Hagerman Audio Labs shall not be liable for errors contained herein or for consequential damages in connection with the furnishing, performance, or use of this material.

Warranty

Hagerman Audio Labs warrants this product free of defects in materials and workmanship for a period of 10 years (90 days on tubes). If you discover a defect, Hagerman Audio Labs will, at its option, repair or replace the product at no charge to you provided you return it during the warranty period, transportation charges prepaid to Hagerman Audio Labs. This warranty does not apply if the product has been damaged by negligence, accident, abuse or misuse or misapplication, has been damaged because it has been improperly connected to other equipment or has been modified without the express written permission of Hagerman Audio Labs. This warranty is limited to the replacement or repair of this product and not to damage to equipment of other manufacturers. Any applicable implied warranties, including warranty of merchantability, are limited in duration to a period of the express warranty as provided herein beginning with the original date of purchase and no warranties, whether express or implied shall apply to the product thereafter. Under no circumstances shall Hagerman Audio Labs be liable for any loss, direct, indirect, incidental, special, or consequential damage arising out of or in connection with the use of this product.

Hagerman Audio Labs

PO Box 26437

Honolulu, HI 96825

808-383-2704 (voice)

808-394-6076 (fax)

www.haglabs.com

Description

The Trumpet is a state-of-the-art MM phonostage that uses balanced feedback-free differential triode gain stages and passive equalization. This topology offers incredible linearity and low distortion combined with unrestricted dynamics and clarity, delivering a hugely open and clear sound. The massive power supply is fully choke regulated for clean, impulse-free current draw from the ac line. The Trumpet has earned a stereophile class "A" recommendation and industry acclaim.

Package Contents

- Trumpet (two chassis)
- Power cord
- Umbilical

Specifications

Item	Specification
Gain	44dB
Input Impedance	47k ohm
Output Impedance	750 ohm
RIAA Response	+/-0.5dB from 20Hz to 20kHz
Bandwidth	5Hz to 250kHz
Distortion	0.03% @1kHz
Noise	75dB ref 5mV A-weighted
Overload	250mV @1kHz
Size	7" x 10" x 4" (each box)
Power	120Vac, 70W
Tube Compliment	12AX7 x 4, 12AU7 x 4

Operation

The Trumpet installs between your turntable and linestage. Be sure to connect the ground lead to the grounding lug near the inputs.

Connect the umbilical cord between the power supply and amplifier chassis. Do NOT operate unit without both boxes connected together and all tubes installed. Connect the power cord to a 120Vac source. Turn on the Heater switch and wait for 30 to 60 seconds. Then turn on the high voltage. Both indicator lamps should now be on. The Trumpet requires about 30 minutes to warm up and sound its best, which is typical of high quality tube equipment. On the amplifier chassis, set both Mute/Polarity switches to the right (or left for inverted signal). Center position is mute.

Tube Rolling

The Trumpet responds admirably to tube rolling. New old stock (NOS) tubes are generally the best, offering various improvements to the sonics. Different tubes sound differently, and the final result becomes a matter of personal taste.

Always replace tubes with their equivalents! Do not use, for example, a 12AT7 in one of the 12AX7 locations. Starting from the rear of the unit (near RCA jacks), the tubes are in order: 12AX7, 12AX7, 12AU7, and 12AU7. It is best to use matched tubes in matched left-right pairs.



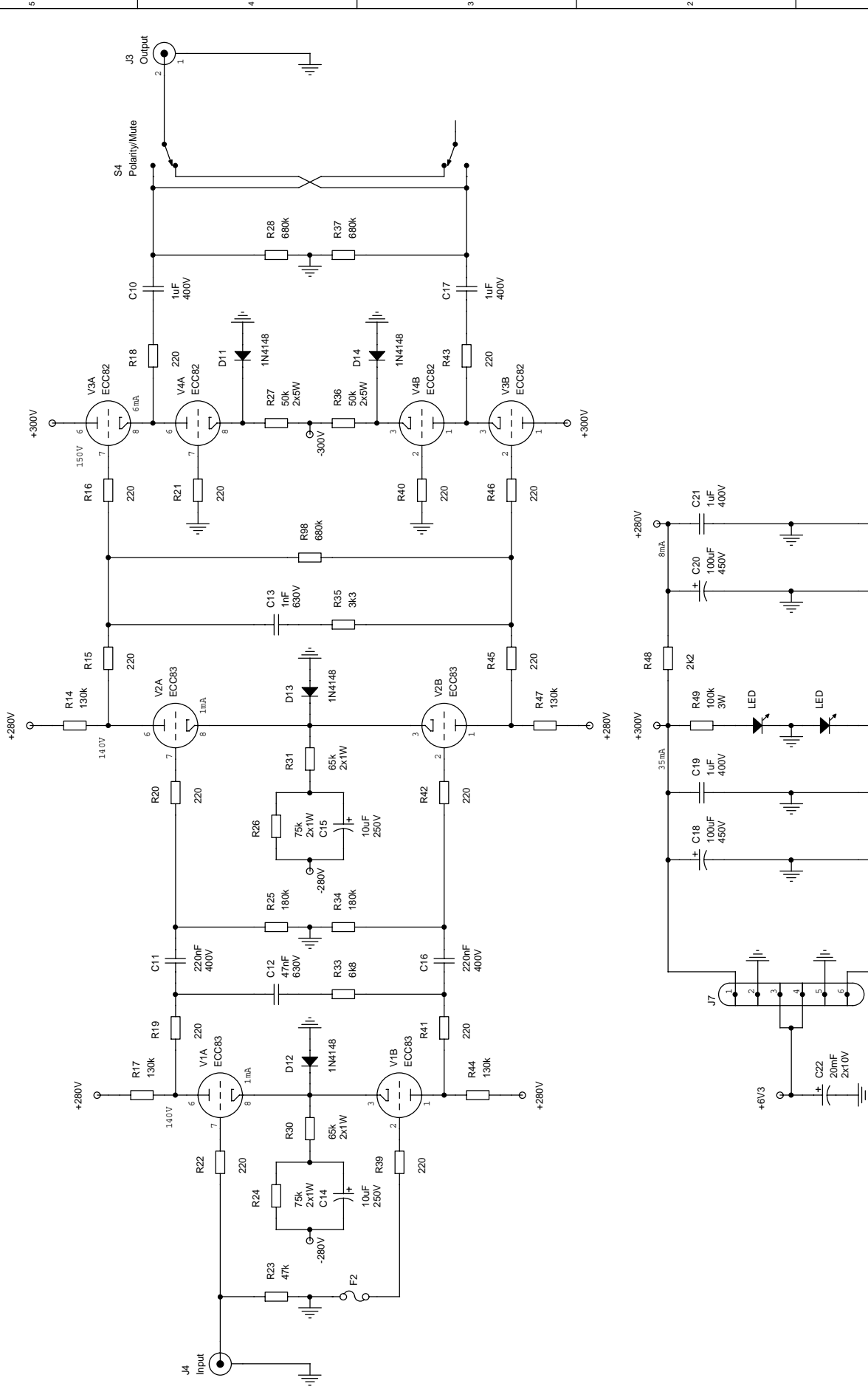

Hagerman Technology LLC
P.O. Box 26497
Honolulu, HI 96825

TRUMPET: Amplifier Left

Title:
Size:
Document Number:
Date: Thursday, April 24, 2008

Sheet 2 of 4

Rev A

Notes:
All resistors 1W unless specified.
R1A4 is 37.5k & 2Hr, 25.8k & 3.3k & 94nF.

This document contains proprietary information and except with written permission of Hagerman Technology LLC such information shall not be published, or disclosed to others, or used for any purpose, and the document shall not be copied in whole or in part. Copyright Hagerman Technology LLC 2008. All rights reserved.

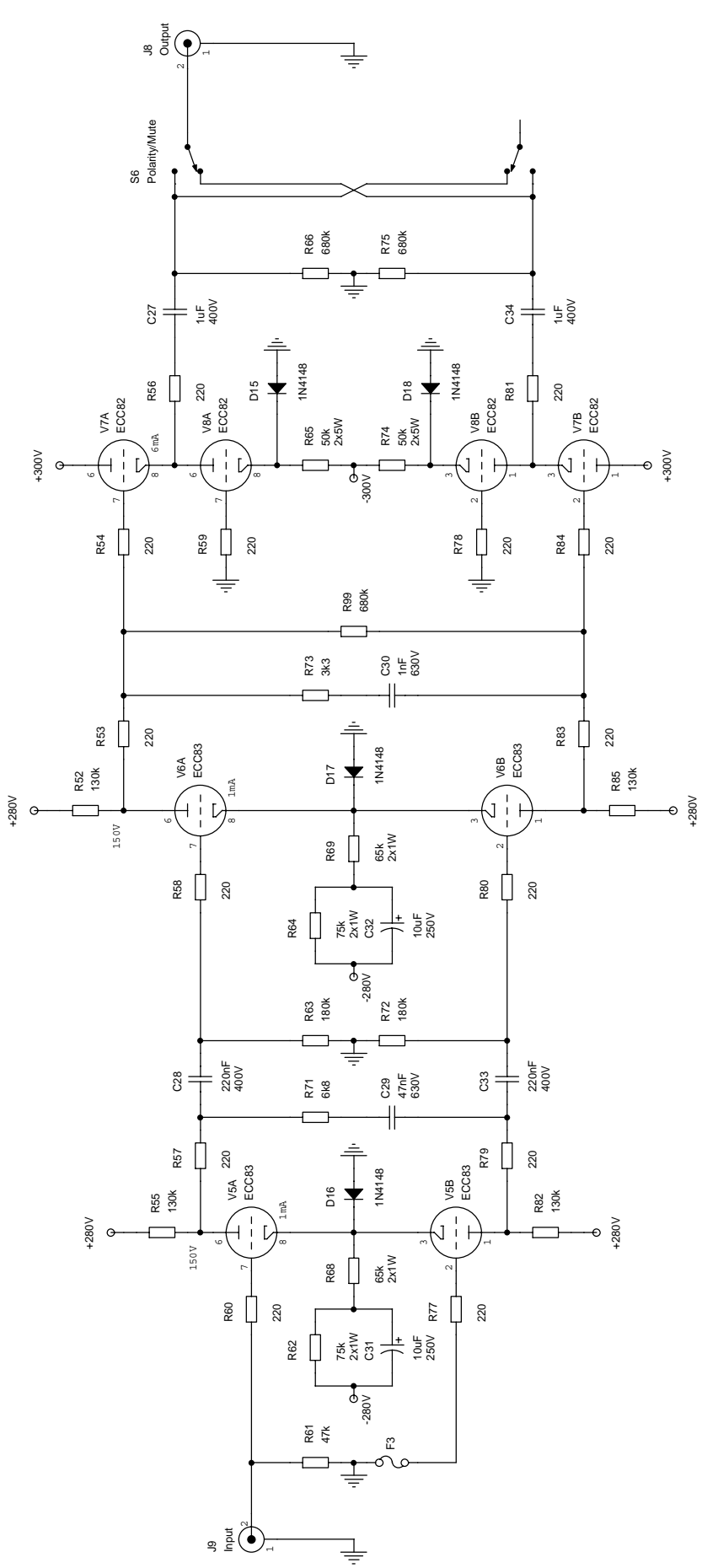

Hagerman Technology LLC
 P.O. Box 26487
 Honolulu, HI 96825
 Title
TRUMPET: Amplifier Right
 Size Document Number
 n/a
 Date: Thursday, April 24, 2008
 Sheet 3 of 4

This document contains proprietary information and except with written permission of Hagerman Technology LLC such information shall not be published, or disclosed to others, or used for any purpose, and the document shall not be copied in whole or in part. Copyright Hagerman Technology LLC 2008. All rights reserved.